

# HP Archive

This vintage Hewlett Packard document was preserved  
and distributed by

**[www. hparchive.com](http://www.hparchive.com)**

Please visit us on the web !

Thanks to on-line curator: Kenneth Kuhn for supplying and  
scanning this vintage document.

T. O. 33A1-6-37-1

# 803A

VHF BRIDGE

SERIAL \_\_\_\_\_

OPERATING AND SERVICING MANUAL



**HEWLETT-PACKARD**  
CORPORATION  
AVENUE  
PACIFIC  
HEWLETT  
CALIFORNIA

## CLAIM FOR DAMAGE IN SHIPMENT

The instrument should be tested as soon as it is received. If it fails to operate properly, or is damaged in any way, a claim should be filed with the carrier. A full report of the damage should be obtained by the claim agent, and this report should be forwarded to us. We will then advise you of the disposition to be made of the equipment and arrange for repair or replacement. Include model number and serial number when referring to this instrument for any reason.

## WARRANTY

Hewlett-Packard Company warrants each instrument manufactured by them to be free from defects in material and workmanship. Our liability under this warranty is limited to servicing or adjusting any instrument returned to the factory for that purpose and to replace any defective parts thereof. Klystron tubes as well as other electron tubes, fuses and batteries are specifically excluded from any liability. This warranty is effective for one year after delivery to the original purchaser when the instrument is returned, transportation charges prepaid by the original purchaser, and when upon our examination it is disclosed to our satisfaction to be defective. If the fault has been caused by misuse or abnormal conditions of operation, repairs will be billed at cost. In this case, an estimate will be submitted before the work is started.

If any fault develops, the following steps should be taken:

1. Notify us, giving full details of the difficulty, and include the model number and serial number. On receipt of this information, we will give you service data or shipping instructions.
2. On receipt of shipping instructions, forward the instrument prepaid, to the factory or to the authorized repair station indicated on the instructions. If requested, an estimate of the charges will be made before the work begins provided the instrument is not covered by the warranty.

## SHIPPING

All shipments of Hewlett-Packard instruments should be made via Truck or Railway Express. The instruments should be packed in a strong exterior container and surrounded by two or three inches of excelsior or similar shock-absorbing material.

**DO NOT HESITATE TO CALL ON US**

**HEWLETT-PACKARD COMPANY**

*Laboratory Instruments for Speed and Accuracy*

275 PAGE MILL ROAD

CABLE



PALO ALTO, CALIF. U.S.A.

"HEWPACK"

T. O. 33A1-6-37-1

OPERATING AND SERVICING MANUAL



MODEL 803A

VHF BRIDGE

SERIAL \_\_\_\_\_



### SPECIFICATIONS

**MEASUREMENT RANGE:** Impedance magnitude, 2 to 2,000 ohms. Higher and lower values may be measured by using a known length of transmission line as an impedance transformer. Phase angle from  $-90^{\circ}$  to  $+90^{\circ}$  at 52 MC and above.

**CALIBRATION:** Impedance: Directly in ohms.  
Phase Angle: Directly in degrees at 100 MC.  
May be readily computed at other frequencies.  
Phase Angle (actual) = Phase Angle (read) x Frequency, MC/ 100.

**ACCURACY:** (Over range 52 to 500 MC.) Impedance magnitude, better than

$$\pm \left( 5 + \frac{\text{Frequency, MC}}{500} \right) \%$$

Phase angle better than  $\pm \left( 3 + \frac{\text{Frequency, MC}}{500} \right)$  Deg.

Charts are provided with each instrument so that impedance readings may be corrected to better than  $\pm 2\%$  and phase angle to better than  $\pm 1.2^{\circ}$  over the entire frequency range.

**FREQUENCY RANGE:** Maximum accuracy 52 to 500 MC. Useful down to 5 MC and up to 1,000 MC. Maximum measurable phase angle at 5 MC is  $-8.80$  to  $+8.8^{\circ}$ .

**EXTERNAL RF GENERATOR:** Requires an AM signal source of at least 1 mw. High signal level is desirable. (Ⓢ Model 608C VHF Signal Generator is ideal for this purpose.)

**RF DETECTOR:** Requires a well-shielded VHF receiver of good sensitivity. (Ⓢ Model 417A VHF Detector, is designed for this use.)

**DIMENSIONS:** Cabinet Mount: 14-1/4" wide, 15-1/4" high, 9" deep.

**WEIGHT:** Net: 28 lbs., shipping: 39 lbs.

**ACCESSORIES PROVIDED:** 1 each Ⓢ 803A-16D Cable Assembly; Ⓢ 803A-16E Cable Assembly.

## CONTENTS

SECTION I	GENERAL DESCRIPTION	PAGE
1 - 1	General . . . . .	I - 1
1 - 2	Damage in Transit . . . . .	I - 1
1 - 3	Auxiliary Equipment Required . . . . .	I - 1
SECTION II	OPERATING INSTRUCTIONS	
2 - 1	Controls and Terminals . . . . .	II - 1
2 - 2	Dial Calibration . . . . .	II - 1
2 - 3	Operating Procedure . . . . .	II - 1
2 - 4	Phase Angle at Frequencies $\neq$ 100 MC . . . . .	II - 2
2 - 5	Multiple Nulls . . . . .	II - 2
2 - 6	Operation with Radiating Loads . . . . .	II - 2
SECTION III	MEASUREMENT INTERPRETATION AND THE Z-THETA CHART	
3 - 1	Direct Measurement . . . . .	III - 1
3 - 2	Remote Measurement, General . . . . .	III - 1
3 - 3	Z-Theta Charts, General . . . . .	III - 1
3 - 4	Z-Theta Chart Description . . . . .	III - 1
3 - 5	Remote Measurement Procedure, Lossless Line . . . . .	III - 2
3 - 6	Remote Measurement, Lossy Line . . . . .	III - 4
3 - 7	Remote Measurement, Lines Other Than 50 ohms . . . . .	III - 6
3 - 8	Correction Charts . . . . .	III - 6
3 - 9	Limitation Remote Measurement . . . . .	III - 6
3 - 10	VSWR Measurement . . . . .	III - 9
3 - 11	Measuring Balanced Impedances . . . . .	III - 9
SECTION IV	THEORY AND MAINTENANCE	
4 - 1	Theory of Operation . . . . .	IV - 1
4 - 2	Accuracy Check . . . . .	IV - 2
4 - 3	Maintenance General . . . . .	IV - 2
4 - 4	Lubrication . . . . .	IV - 2
SECTION V	TABLE OF REPLACEABLE PARTS	
5 - 2	Table of Replaceable Parts . . . . .	V - 2

# SECTION I

## GENERAL DESCRIPTION

### 1-1 GENERAL

The Model 803A VHF Bridge operates on the Byrne-bridge principle<sup>1</sup> which separately couples to the E and M fields in a transmission line. Two attenuators are controlled simultaneously, one responds to the E field while the other responds to the M field. Both are adjusted for equal output. The resulting signals are applied to opposite ends of a slotted line section. Impedance phase angle is determined by the location of the cancellation point in the slotted section as detected by a sliding probe.

This bridge arrangement covers the frequency range from 50 MC to 500 MC and measures impedance directly in the range from 2 to 2000 ohms. Phase angle of the impedance is measured directly at 100 MC, but is readily computed at other frequencies.

### 1-2 DAMAGE IN TRANSIT

Should shipping damage be in evidence upon unpacking this instrument, follow the procedure out-

---

<sup>1</sup>Byrne, J. F., "A Null-Method for Determination of Impedance in the 100-400 MC Range", Proc. Nat'l Elec. Conf., Vol. 3, p. 603, 1947.

lined in the "Claim for Damage" section in this manual.

### 1-3 AUXILIARY EQUIPMENT REQUIRED

To operate the Model 803A a signal source of the desired frequency must be connected to the GENERATOR terminal, and a receiver which will respond to this frequency must be connected to the DETECTOR terminal.

**RF GENERATOR.** The signal generator driving the bridge should have a power output of at least one milliwatt, and be capable of amplitude modulation. One of the Hewlett-Packard Model 608 VHF Signal Generators is recommended for this application.

**RF DETECTOR.** The detector used with the bridge should be a receiver preferably with a sensitivity at least 90 db below the signal-generator level. This detector must be thoroughly shielded since any spurious signal of the test frequency picked up by the receiver in a manner other than the slotted section probe will result in an indeterminate balance and inaccurate results. The Hewlett-Packard Model 417A VHF Detector was specifically designed for use with the Model 803A and is recommended for this application.



## SECTION II OPERATING INSTRUCTIONS

**CAUTION:** THERE IS NO REASON FOR REMOVING THE REAR COVER OF THE INSTRUMENT.

Experience has shown that many bridges are damaged by removing the rear cover, particularly if the PHASE dial is not set to  $45^\circ$  before removing the cover.

### 2-1 CONTROLS AND TERMINALS

**GENERATOR** - This BNC jack accepts a source signal to drive the bridge.

**UNKNOWN** - This type N terminal accepts the unknown impedance to be measured.

**SHORTING PLUG** - This plug is used to check the accuracy of the instrument as described in paragraph 4-2.

**DETECTOR** - This BNC jack accepts the detector connection.

**MAGNITUDE** - This control adjusts the position of the attenuators and drives the dial which gives the impedance magnitude at balance.

**PHASE** - This control is ganged to the probe which moves in the slotted section around the bridge and drives the dial indicating impedance phase angle at balance.

### 2-2 DIAL CALIBRATION

The concentric indicating dials on the Model 803A read out impedance and phase angle. The upper dial indicates impedance directly in ohms independent of frequency. The lower dial indicates phase angle at 100 MC. The positive phase angle calibrations in black indicate an inductive reactance. The negative phase angle calibrations in red indicate a capacitive reactance. To obtain impedance phase angle at any frequency, see para. 2-4.

### 2-3 OPERATING PROCEDURE

The recommended arrangement for conducting measurement tests with the Model 803A is shown in Figure 2-1.

When the signal generator is operating at the desired frequency, the receiver is tuned until a signal is heard. Should the bridge chance to be at balance, the signal may be difficult to detect, and it is advisable to move the PHASE and MAGNITUDE controls slightly to obtain a loud working signal. When the bridge is operating correctly the signal at unbalance will be approximately 40 db below the level of the signal at the bridge input.

When the working signal has been obtained the PHASE and MAGNITUDE controls are adjusted until a sharp null is obtained. When the knobs have been adjusted for an absolute null, the impedance magnitude and phase angle may be read directly from the dials on the VHF Bridge.

The nulls obtained by the bridge under the proper conditions of receiver sensitivity and signal level are extremely sharp at high frequencies and shallow at low frequencies and may be difficult to locate under certain conditions. When the approximate value of the impedance is known, however, the null is detectable without difficulty.

When the approximate value of the impedance under test is not known, the following procedure should be used.

- 1) Reduce either the signal level from the generator or reduce the sensitivity of the receiver until the signal is barely audible.

When the Model 417A VHF Detector is employed, use the QUENCH control rather than the VOLUME control for this operation.

- 2) Adjust the PHASE and MAGNITUDE controls for a reduction in the signal level. The sequence of this adjustment is not important, and the controls may be adjusted simultaneously. With a low signal level or a low detector sensitivity, the region of the null is easily located.



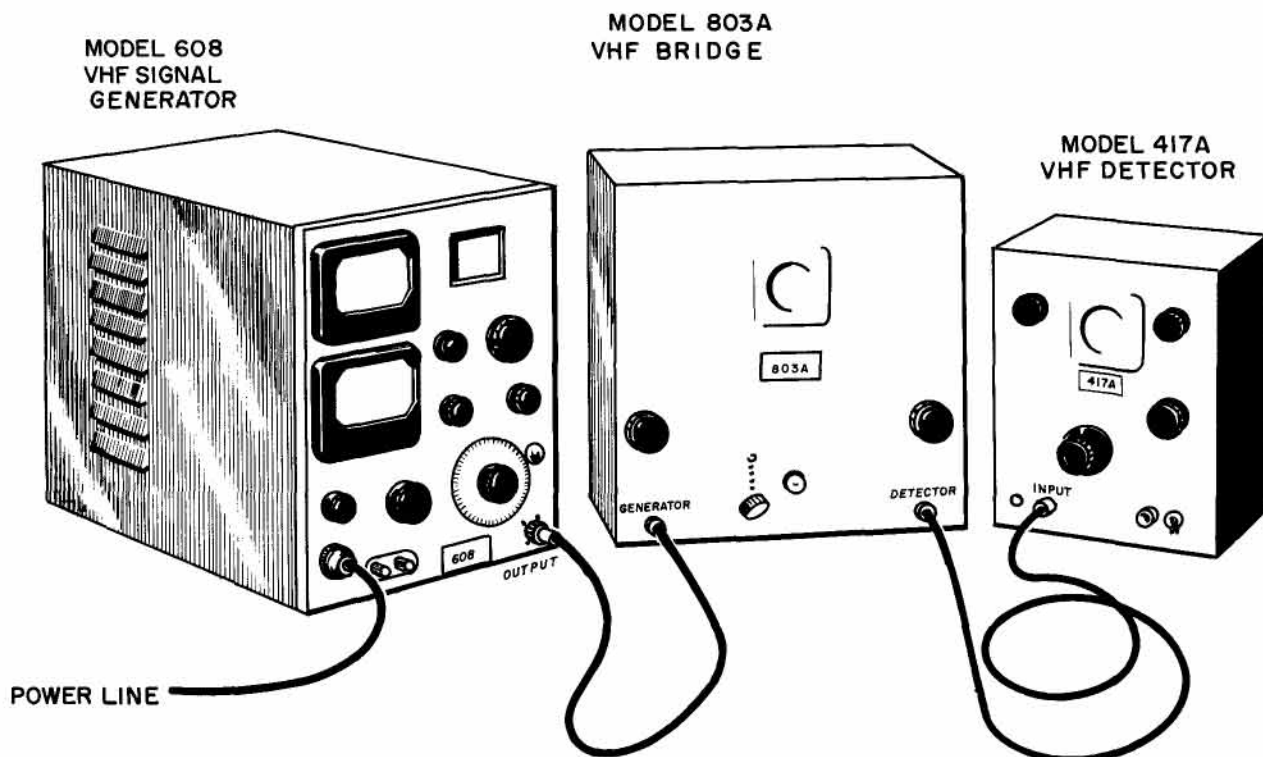

Figure 2-1. Arrangement of Test Equipment

3) When the null region has been established, increase the signal level or sensitivity of the receiver and adjust the controls for further localization of the null. As the null is localized, continue to increase the signal level until the final null is obtained.

#### 2-4 PHASE ANGLE AT FREQUENCIES $\neq 100\text{MC}$

The nature of the bridge permits the PHASE control to be calibrated at any single frequency. The impedance phase angle of any other frequency is defined by the ratio of the actual frequency to the calibrated frequency. To facilitate calculation, the PHASE dial on the Model 803A is calibrated for a frequency of 100 MC. The actual phase angle is determined by the expression:

$$\theta = \frac{\text{signal frequency}}{100 \text{ MC}} \times (\text{Dial reading } \theta)$$

#### 2-5 MULTIPLE NULLS

At high frequencies it is possible to obtain several nulls on the phase dial. The significant null is the one which is closest to the zero on the PHASE dial. This condition exists because most impedance phase angles will fall between  $-90^\circ$  and  $+90^\circ$  and as the frequency is increased, the corresponding dial range is decreased. For example, at 300 MC, a phase angle range from  $-90^\circ$  to  $+90^\circ$  represents a dial range from  $-30^\circ$  to  $+30^\circ$ . (See para. 2-4.)

#### 2-6 OPERATION WITH RADIATING LOADS

In many cases measurement will be conducted for antenna impedance or other load impedances under conditions where appreciable radiated energy is present around the bridge and the detector. The Model 803A has been carefully checked for leakage, and the Model 417A VHF Detector has been designed with shielding for such applications. However, a very small amount of leakage into the detector will cause erroneous results.

When a radiating load is located close to the bridge, a well-shielded cable must be used connecting the bridge to the detector.

Ordinary RF double braid shielded cable is inadequate in some cases, and copper-clad cable should be used with both ends of the cable carefully grounded to the connectors. This precaution is normally adequate for satisfactory results with radiating loads.

When the shielding is adequate, bridge balances will be sharp and unaffected by touching or grounding various parts of the bridge circuit or cables.

Inadequate shielding will reveal itself as inconsistent repeat results, and as a shifting null when the receiver or bridge is touched or grounded.

# SECTION III MEASUREMENT INTERPRETATION AND THE Z-THETA CHART

## 3-1 DIRECT MEASUREMENT

The Model 803A measures load impedance at a point in the line, located by design considerations, 3 cm behind the UNKNOWN panel connector. Although this length has been made as short as possible circumstances arise in which the actual impedance is transformed by this length of line, and the 803A will not give the desired impedance directly. At high frequencies this condition may become quite pronounced even with the load connected directly across the bridge terminal.

This length of line is equivalent to a series inductance of  $0.0059 \mu\text{h}$  and a shunt capacitance of  $2.45 \mu\mu\text{f}$  when loads are connected directly across the bridge terminal, and the impedance reading may be corrected by the use of the equivalent circuits shown in Figure 3-1 or by the use of the  $Z - \theta$  chart, paragraph 3-5.

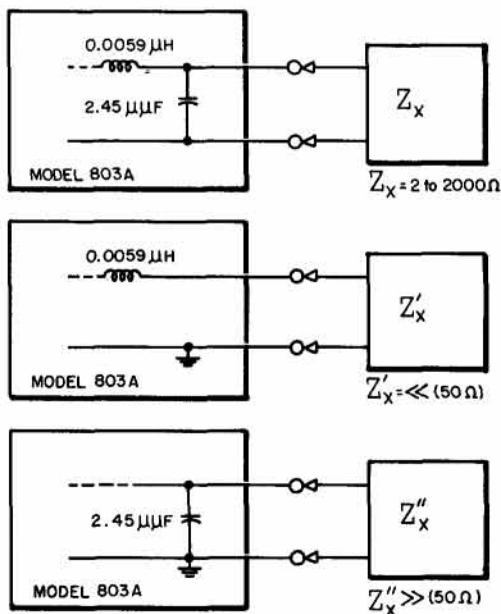

Figure 3-1. Equivalent Circuits for Internal Line Length

## 3-2 REMOTE MEASUREMENT, GENERAL

In many cases it is desired to connect the impedance under test to the bridge through a length of transmission line. When this is done the load impedance is transformed by whatever line length is used and a correction must be applied to the reading of the bridge to give the actual impedance.

The correction to be applied is found by the use of a  $Z$ -Theta chart described in paragraphs 3-3, through 3-8.

## 3-3 Z-THETA CHARTS, GENERAL

Two transparent films of the  $Z - \theta$  chart will be found in the back of this instruction manual. One chart has a center value of 50 ohms ( $Z_0 = 50$  ohms) for direct use with 50 ohm systems. The other chart is normalized with  $Z_0 = 1$  for use in other systems. Dry process prints can be made from these transparencies for use with the 803A bridge.

## 3-4 Z-THETA CHART DESCRIPTION

The  $Z - \theta$  chart is an impedance coordinate system used for the graphical solution of transmission line problems<sup>1,2</sup> similar to the better known Smith Chart.<sup>3</sup> While the Smith Chart is based upon a rectangular coordinate system for impedance or admittance, the  $Z - \theta$  chart is constructed

<sup>1</sup>Ragan, G. L. et al; MICROWAVE TRANSMISSION CIRCUITS Vol. 9, MIT RAD LAB), Section 2-12, McGraw-Hill, New York, 1948.

<sup>2</sup>Terman, F. E., Pettit, J. M., ELECTRONIC MEASUREMENTS, p. 157, McGraw-Hill, New York, 1952.

<sup>3</sup>Smith, P. H., "An Improved Transmission Line Calculator" "Electronics", p. 130, January 1944.

as a polar coordinate system. Such a chart is shown in Figure 4 with a description of the elements.

For purposes of illustration, referring to Figure 3-3, assume that a 50 ohm transmission line with negligible loss is being used and that a bridge reading has been taken and frequency corrected according to paragraph 2-4, to a value of 20 ohms  $\angle +40^\circ$ .

This point, labeled A, is plotted on the chart, and it represents the impedance of the load as seen from the bridge (generator).

If a circle is drawn on the chart with its center at the 50 ohm  $\angle 0^\circ$  point with the circumference passing through point A, the entire line is described by the chart and the circle. The circle is one of constant Standing Wave Ratio, and is the locus of input impedance points as the line length varies. Movement around the circle is effectively movement along the line.

Starting at point A, the bridge, and moving toward the load (effectively moving the bridge toward the load), various points along the line are described by the chart.

As the bridge moves one-eighth wave-length, 45 electrical degrees, toward the load it sees point B as 31 ohms  $\angle -54^\circ$ .

Moving one-quarter wavelength, 90 electrical degrees, toward the load the bridge sees point C as 125 ohms  $\angle -40^\circ$ .

At the half-wavelength point, the bridge sees point A repeated.

Starting at point A again, assume that point A represents the actual load, instead of what the bridge sees through a length of line. In this case the bridge would see point A when connected across the load terminals, and at each half-wavelength away from the load. At a point one-eighth wavelength away from the load, the bridge would see point D, 81 ohms  $\angle +54^\circ$ .

### 3-5 REMOTE MEASUREMENT PROCEDURE, LOSSLESS LINE

When measurement is made at a point remote from the load, corrections to the measured impedances are determined by the effects of the line. Theoretically, a transmission line could be physically measured, its length converted to wavelengths at operating frequency, and the  $Z-\theta$  chart entered with this length to determine the actual load impedance. Practical considerations however, would render the results inaccurate. In practice, the effect of line transformation is established by comparing a load of known characteristics, usually a short circuit, with its bridge reading. The procedure is illustrated in the example below. The example assumes that the transmission line from the load to the bridge has negligible loss and a characteristic impedance of 50 ohms, as shown in Figure 3-2.

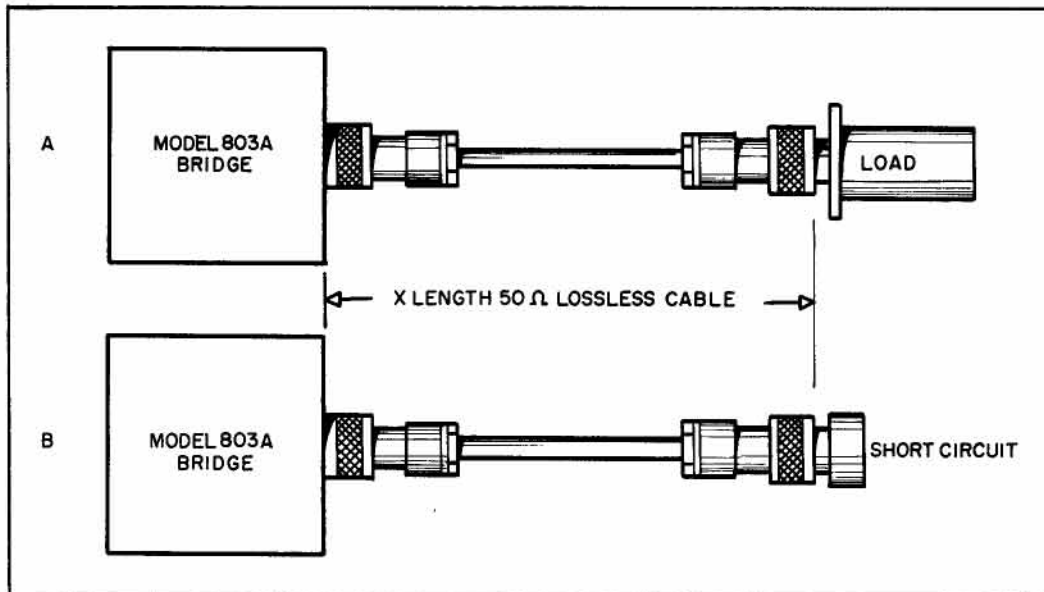
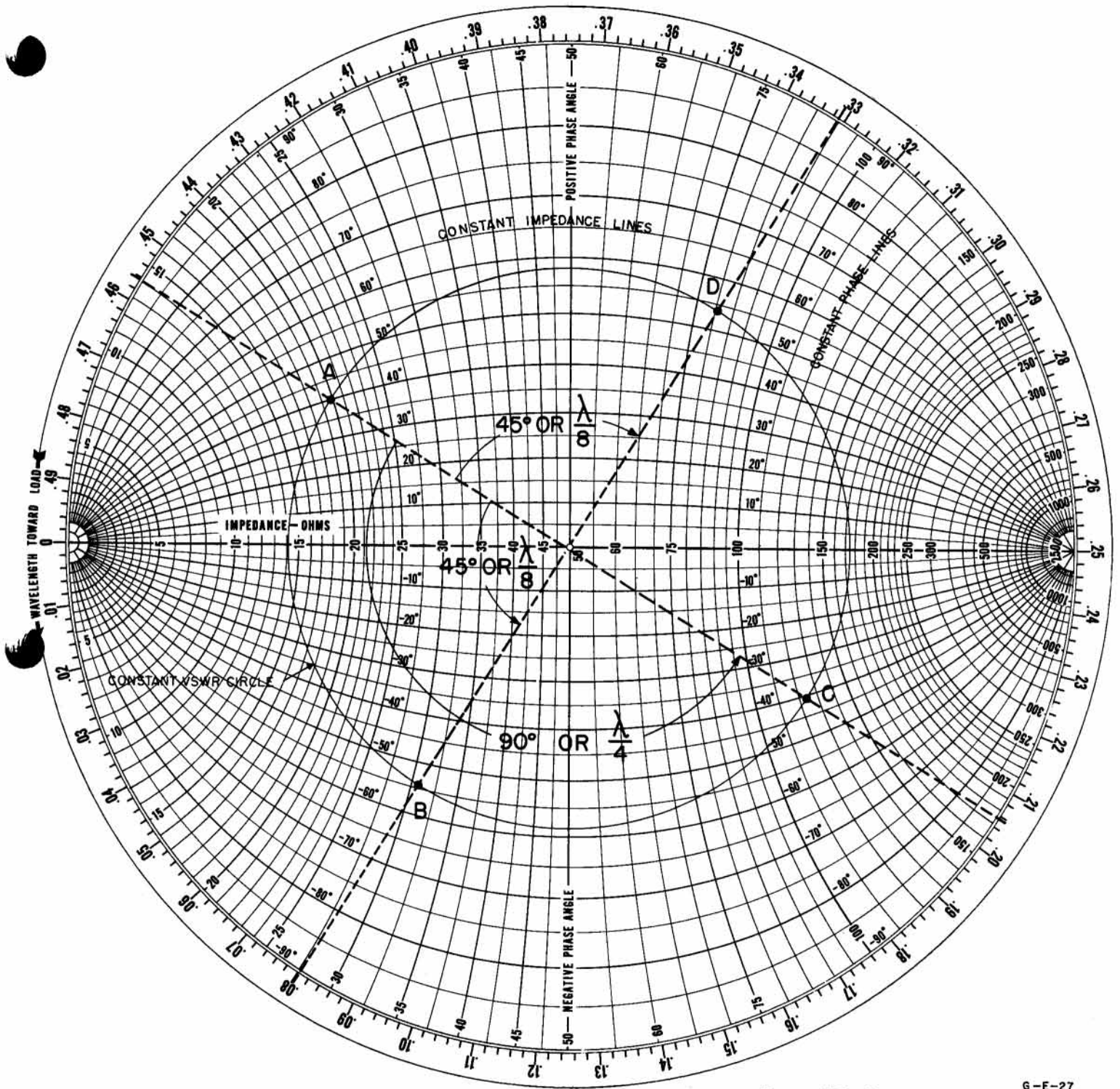

Figure 3-2. Remote Measurement Connections



$Z_0 = 50 \Omega$

G-E-27

**Z- $\theta$  CHART**  
**MODEL 803A VHF BRIDGE**  
HEWLETT-PACKARD COMPANY  
PALO ALTO, CALIFORNIA

Figure 3-3. Z-Theta Chart Description



- 1) Assume the source frequency is 180 MC, and that dial readings were obtained: 120 ohms  $\angle -20^\circ$ .
- 2) With the frequency correction (paragraph 2-4) the load as seen by the bridge at the end of the line is: 120 ohms  $\angle -36^\circ$ . This point is plotted as point A in Figure 3-4.
- 3) Draw a line from the center of the chart, through point A, to the periphery of the chart, point B (.207 wavelength).
- 4) Remove the load and connect a short circuit to the transmission line as shown in Figure 3-2B. (See paragraph 3-9.)
- 5) Assume that the bridge, reading the short, indicates: 114 ohms  $\angle +50^\circ$ , and that this reading is corrected for a frequency of 180 MC to: 114 ohms  $\angle +90^\circ$ . The corrected reading is plotted on the chart as point S.
- 6) Since the short circuit is actually zero impedance, and not 114 ohms  $\angle +90^\circ$ , we can assume that the short seen by the bridge has been transformed by the transmission line.

On the wavelength scale point S reads .316 wavelength while the actual zero impedance point (point O) reads .500 (or .000) wavelength. This shows us that what the bridge sees as point S is a point which is moved away from the actual short-circuit (therefore clockwise on the chart) an effective distance of .184 wavelength. Therefore, the bridge reading (point A) for the unknown impedance must be transformed toward the load over an effective distance of .184 wavelength to obtain the actual impedance - as though we moved the bridge physically through a length of line, toward the load .184 wavelength, to read the actual impedance at the nearest one-half wavelength point from the load. To accomplish this, continue with step 7.

- 7) Rotate point B toward the load (counter-clockwise) on the chart through .184 wavelength to point C which reads .391 wavelength.
- 8) Construct a radius from the center of the chart (K) to point C.
- 9) Scribe an arc with radius KA through line KC. The intersection is labeled point D.

The arc is part of the constant Standing Wave Ratio circle described in paragraph 3-4 which is

used in the case of the lossless line, but would not be used in the lossy line case discussed in paragraph 3-6.

- 10) Point D represents the actual load impedance 42 ohms  $\angle +54^\circ$ .

### 3-6 REMOTE MEASUREMENT, LOSSY LINE

Figure 3-5 illustrates the effect of a lossy line for a given load  $Z/\theta$ . The actual impedance of the load is shown on the chart as point A. As the point of measurement is moved down the line away from the load point A, the locus of the input impedance points describes a logarithmic spiral, instead of the circle in the lossless case. This SWR spiral, an exponential function of line loss per unit length, approaches the center of the chart with each rotation.

When the transmission line loss was negligible, as in paragraph 3-5, impedances were transformed along the line on a circle of constant SWR. Movement around the chart on the circle was the same as movement along the line itself.

When the transmission line is lossy, the SWR decreases as the line length is increased, and the impedances are transformed along the spiral. In the lossless case, the phase angle of a short circuit was  $90^\circ$ . In the lossy case, the short-circuit phase angle will be less than  $90^\circ$ , and the departure which the measured phase angle exhibits from  $90^\circ$  will be used to proportion the effect of the line upon the actual impedance under test.

**PROCEDURE** - The procedure for impedance measurement with a lossy line is the same as that described in paragraph 3-5 with the exception that a line loss correction is made on the final transformed impedance. The procedure is demonstrated in the following example and plotted on Fig. 3-6.

- 1) An impedance is measured, frequency corrected, and plotted as point A.
- 2) A radius from K is projected, through point A, to the periphery of the chart, point B.
- 3) The load is replaced with a short circuit, the reading is frequency corrected, and plotted as point S. A radius is projected from K, through S, to point T.

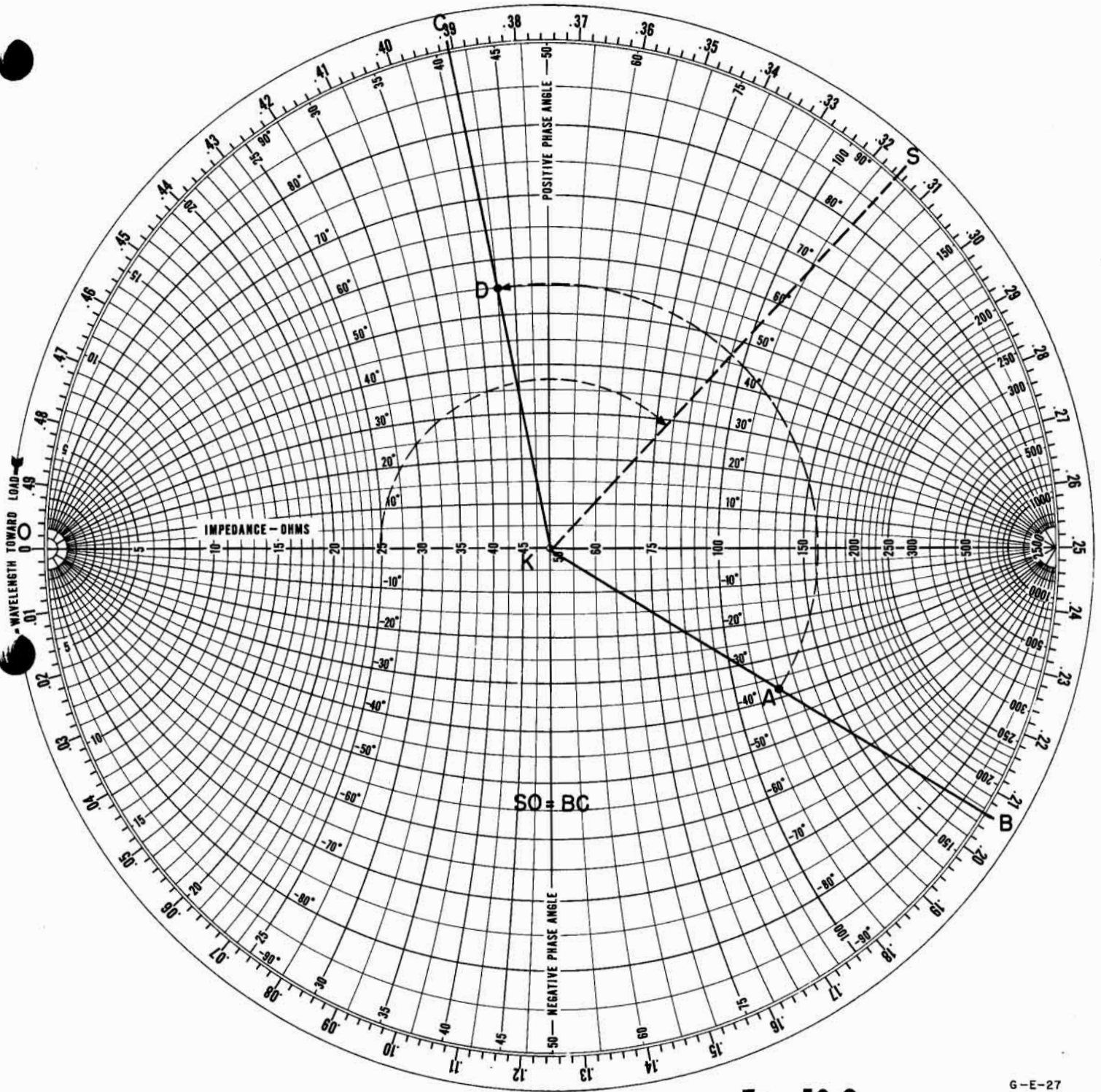

$Z_0 = 50 \Omega$

G-E-27

**Z-θ CHART**  
**MODEL 803A VHF BRIDGE**  
HEWLETT-PACKARD COMPANY  
PALO ALTO CALIFORNIA

Figure 3-4. Correction for Transmission Line Length

4) The impedance seen by the bridge, point S, has been transformed by the length of the transmission line away from the known zero impedance, point O, .420 wavelength around the chart. Therefore, the bridge reading for the unknown load, point A, must be transformed toward the load .420 wavelength to obtain the actual impedance. For convenience we can assume that point S may be moved to the nearest half-wavelength point away from the load to read the actual short. This distance is .08 wavelength clockwise on the chart from point T to point O, since point O represents what the bridge sees at the load and at each half-wavelength away from the load (neglecting losses in the line).

Transforming point B to the nearest half-wavelength point on the line is accomplished by moving around the chart with the same magnitude and direction as arc TO; in this case .08 wavelength clockwise to point C on the chart.

5) Construct the actual load impedance for the lossless case, point D, by drawing an arc with radius KA through line KC. The intersection is labeled point D.

6) Point E represents the actual load impedance and phase angle for the lossy line case. It is determined from the following proportion:

$$KE/KD = KT/KS$$

In the above example the number of wavelengths of rotation which point E undergoes to reach point A (the measured impedance) is equivalent to the number of wavelengths in the line between the load and the point of measurement. The number of times which point E rotates, however, does not affect the method of solution described.

### 3-7 REMOTE MEASUREMENT, LINES OTHER THAN 50 OHMS

The procedures in paragraphs 3-5 and 3-6 also apply to loads connected across the bridge through transmission lines with a characteristic impedance other than 50 ohms. In such cases the impedance readings are normalized around the actual line impedance by dividing all impedances of interest by the characteristic line impedance. Plotting is then carried out on the normalized  $Z-\theta$  chart. ( $Z_0 = 1$ ) See paragraph 3-3.

### 3-8 CORRECTION CHARTS

The Model 803A can be expected to give impedance indications within  $\pm 5 + \frac{(\text{Freq. MC})}{500}$  percent for impedance magnitude and within  $\pm 3 + \frac{(\text{Freq. MC})}{500}$  degrees for phase angle without further correction except for the line length corrections discussed in paragraphs 3-5 and 3-6.

When greater accuracy is desired the specific correction charts, supplied in the back of this manual, should be used. These correction charts can be used directly for three particular cases: when the impedance phase angle is  $+90^\circ$ ,  $0^\circ$ , and when it is  $-90^\circ$ . On both charts proportionate corrections may be applied to obtain corrections when phase angles between those charted are obtained.

On the IMPEDANCE CORRECTION CHART for phase angles between  $0^\circ$  and  $90^\circ$  the correction factor may be interpolated in accordance with a sine wave function. For example, if the phase angle is  $60^\circ$ , 0.866 of the difference between the two correction factors is used. If the phase angle is  $45^\circ$ , 0.707 of the difference between the two correction factors is used.

On the PHASE ANGLE CORRECTION CHART the correction factor is interpolated on a linear basis. For example, if the phase angle is  $45^\circ$ , one-half the difference between the correction factor for zero degrees and the factor for  $90^\circ$  is used.

Although the interpolation is not absolute in all cases, it is usually possible to achieve a bridge accuracy of 1% using the above procedure. The accuracy is even better for the three specific cases given on the charts.

### 3-9 LIMITATION REMOTE MEASUREMENT

In a short-circuited transmission line impedance minima and maxima occur at quarter-wavelength multiples down the line, and the magnitudes will fall outside the measurement range of the bridge which is from 2 to 2000 ohms. If this condition occurs, the frequency of operation should be changed slightly since a very small change in frequency will shift the quarter-wavelength points enough to make accurate measurements.



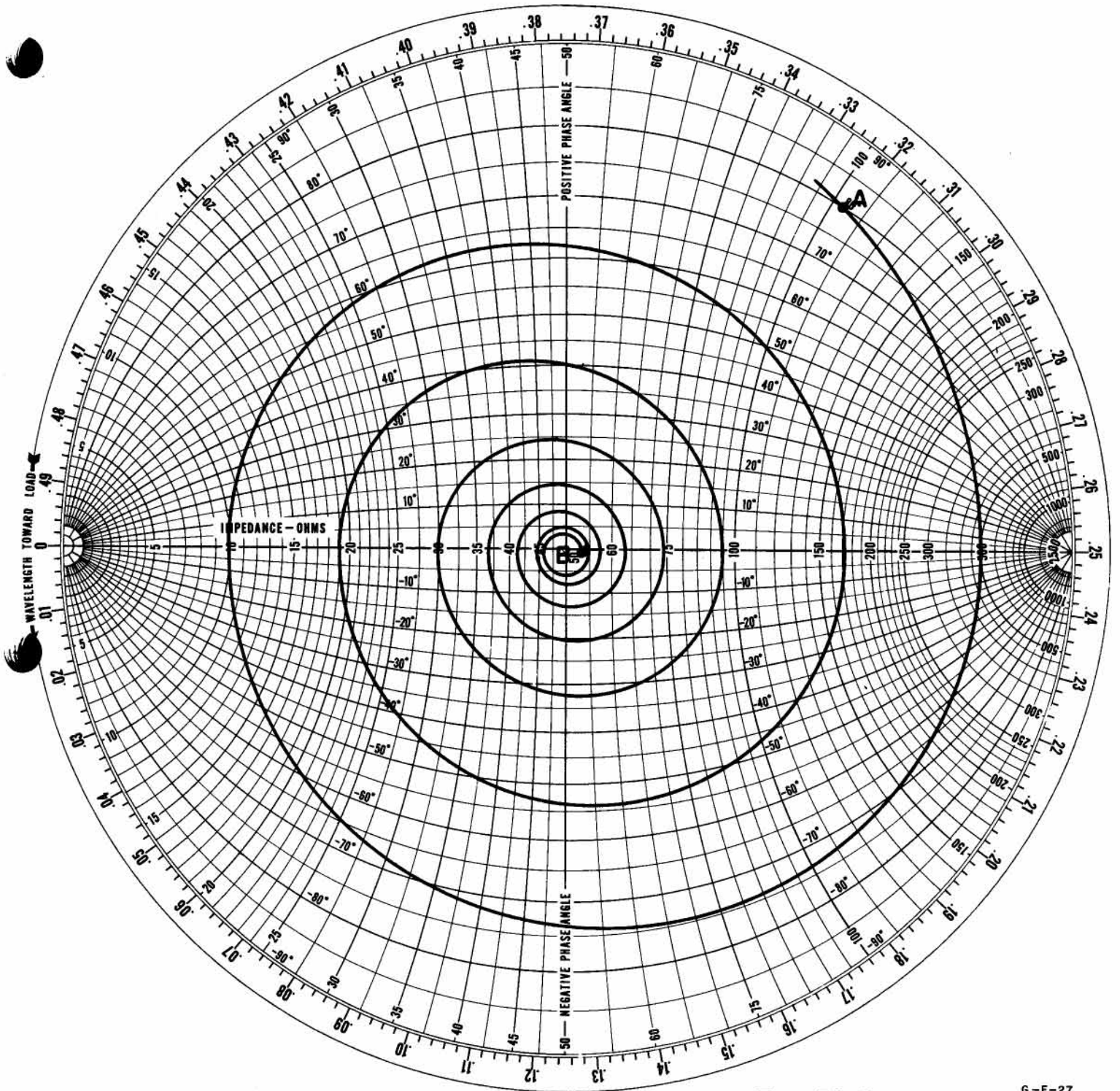

$Z_0 = 50 \Omega$

6-E-27

**Z -  $\theta$  CHART**  
**MODEL 803 A VHF BRIDGE**  
HEWLETT-PACKARD COMPANY  
PALO ALTO, CALIFORNIA

Figure 3-5. Effects of Lossy Line (Loss: 4 db/wavelength)

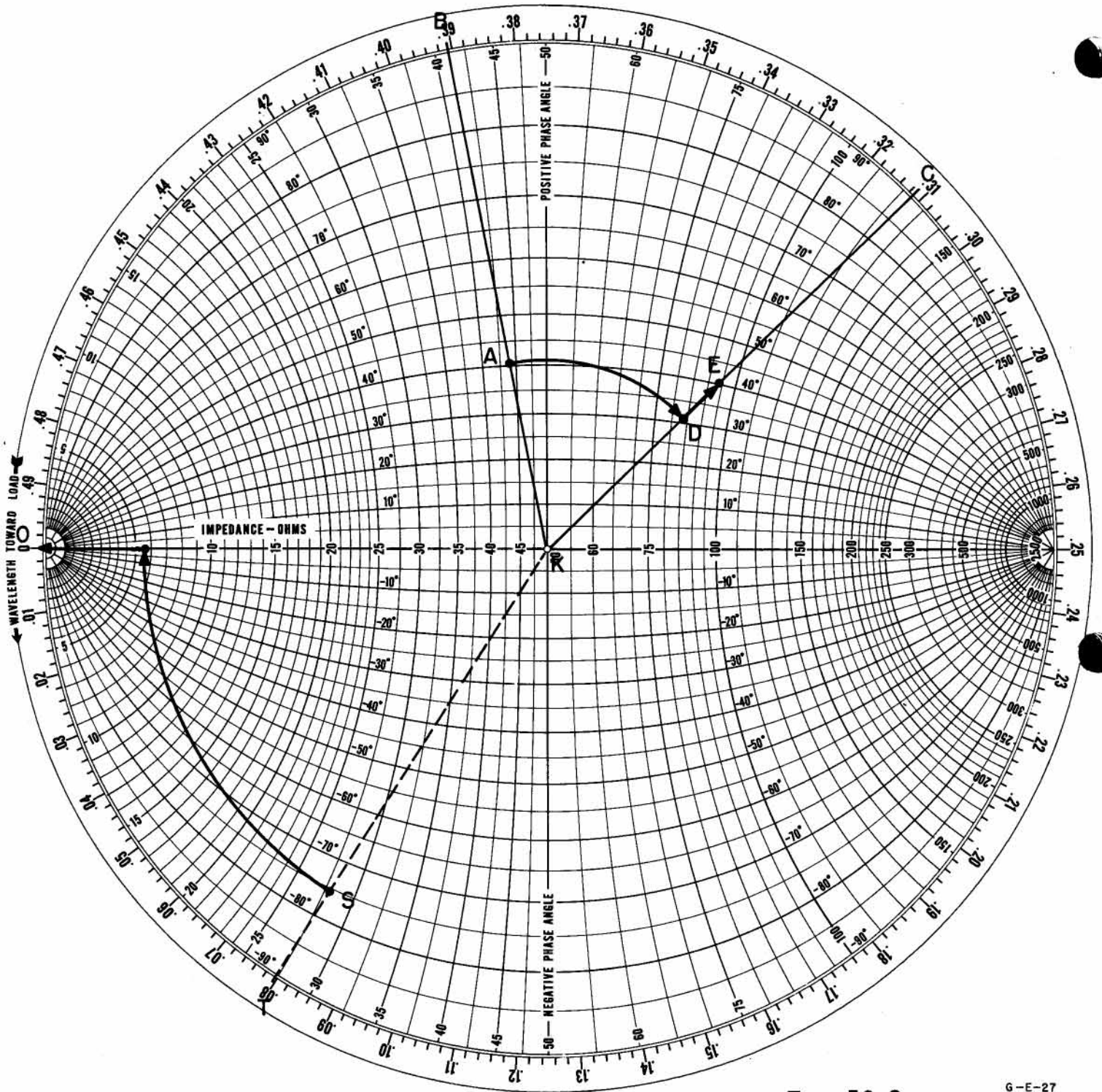

$Z_0 = 50 \Omega$

G-E-27

# Z-θ CHART MODEL 803A VHF BRIDGE

HEWLETT-PACKARD COMPANY  
PALO ALTO CALIFORNIA

Figure 3-6. Measurement with Lossy Line

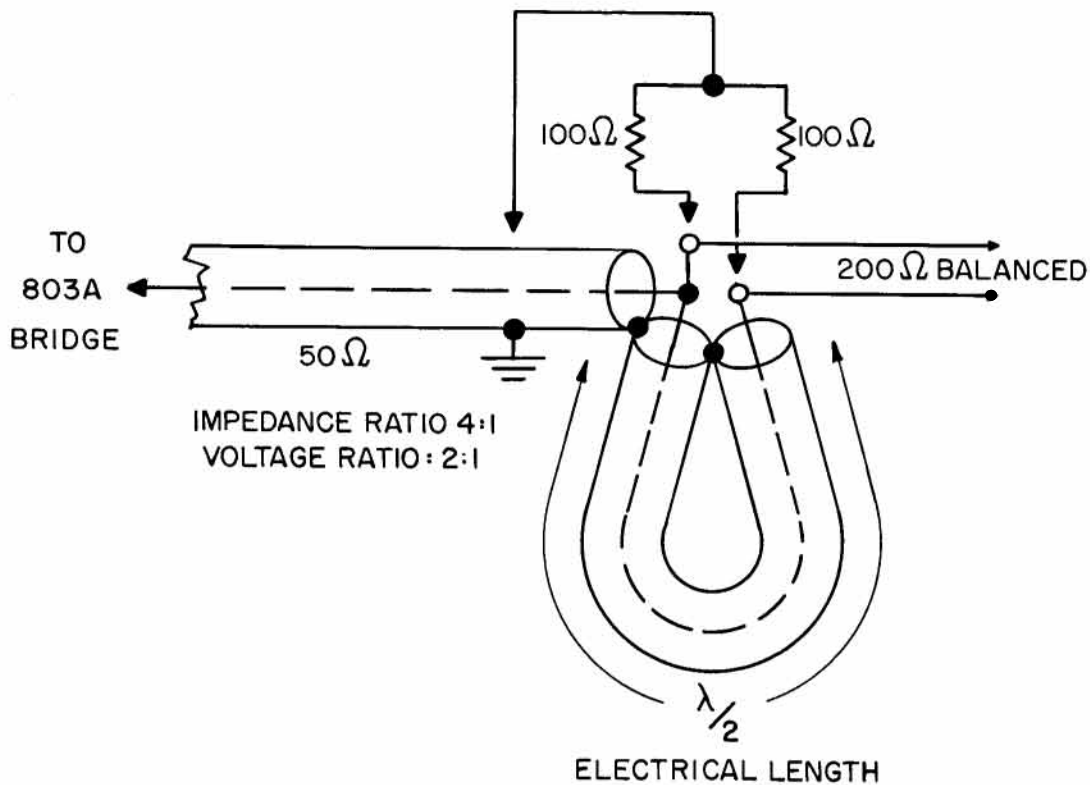

Figure 3-7. Simple Balun to Operate from Balanced System

### 3-10 VSWR MEASUREMENT

VSWR of a system under test can be determined with a single impedance measurement plotted on the  $Z-\theta$  chart. The procedure is as follows:

- 1) Plot the bridge reading, frequency corrected, on the  $Z-\theta$  chart.  $Z_0 = 50\ \Omega$ .
- 2) Construct a constant VSWR circle, centered in the middle of the chart, which passes through the plotted impedance point. Scribe this circle until it intersects the right hand horizontal axis of the chart.
- 3) The VSWR is given by the value of the intercept point divided by 50 ohms.

In transmission line systems other than 50 ohms, the normalized  $Z-\theta$  chart is used, ( $Z_0 = 1$ ). The procedure is the same as that described above except the measured impedance is normalized by dividing it by the characteristic impedance of the system and then plotted on the chart. A circle with its center at the middle of the  $Z-\theta$  chart is scribed through the plotted impedance point. The intercept of this circle with the right side of the horizontal axis gives the VSWR directly.

### 3-11 MEASURING BALANCED IMPEDANCES

A type of measurement often required is the measurement of balanced impedances, such as balanced antennas fed by a balanced transmission line. Since the UNKNOWN terminal on the Model 803A operates at ground potential it is a single ended instrument, and a balancing device is required when measuring balanced unknown impedances.

A suitable device for converting balanced to unbalanced systems is the balun shown in Figure 3-7. The balun is cut exactly one-half wavelength long at the operating frequency so that the voltage at the input to the balun will be reproduced out of phase at the load end of the balun. The balun effectively drives one-half the load while the bridge drives the other half, making the voltage across the load equal to twice the voltage delivered by the bridge. This system is generally equivalent to a 1:2 voltage transformer, or a 1:4 impedance transformer. Readings made by the bridge will be one-fourth of the actual impedance magnitude of the load. Phase angle measurements theoretically are not transformed by the balun.

The balun shown in Figure 3-7 is easily constructed and is not difficult to adjust. For normal use and accuracy a 10% bandwidth ( $\pm 5\%$  deviation) can be covered. More precise results are possible when the bandwidth is reduced to a  $\pm 1\%$  deviation. The system is inherently narrow banded and must be adjusted when the frequency is changed by an appreciable amount.

**BALUN CONSTRUCTION.** Using suitable low loss coaxial cable, such as 55/U, 58/U, 8/U, or 9/U, cut a section which is slightly greater than one-half wavelength computed for the frequency desired. The propagation constant, for the coax above, is  $2/3$  the wavelength of air propagated waves.

It is suggested that about 70% of the air propagated one-half wavelength of the desired frequency be used for the initial balun length, subject to later adjustment. The balun arrangement should be constructed as shown in Figure 3-7 with particular attention being given the grounding arrangement. The line length which connects the balun to the bridge is not critical, but should have low loss.

**ADJUSTING THE BALUN.** When the balun has been connected to the VHF Bridge, and the desired frequency is driving the system, short circuit the bridge side of the balun. Plot the reading, frequency corrected, on the applicable Z- $\theta$  chart.

After removing the short circuit, above, establish a new short circuit at the end of the balun away from the bridge (load side), and plot the reading as before.

If these two readings agree, the balun is exactly  $1/2$  wavelength long and may be used for the established frequency without further adjustment.

Since we deliberately made an extra allowance for length, however, the second bridge reading should not agree with the first. On the Z- $\theta$  chart, the first reading establishes a reference impedance and phase angle ( $\theta$  will be  $90^\circ$  positive or negative depending upon the length of line from the balun to the bridge).

When the second short-circuit reading is taken, the generator effectively moves one-half wavelength away from the load, and the reference

point effectively moves clockwise around the chart. The reference point will move exactly one revolution ( $1/2$  wavelength) in the ideal case, but the balun was cut deliberately greater than one-half wavelength, and the second point rotates slightly more than one revolution. Looking at the Z- $\theta$  chart, it can be seen that if the phase angles of the readings are negative the second impedance will be less than the first, and if the phase angles are positive the second impedance magnitude will be greater than the first, because of rotation greater than one-half wavelength.

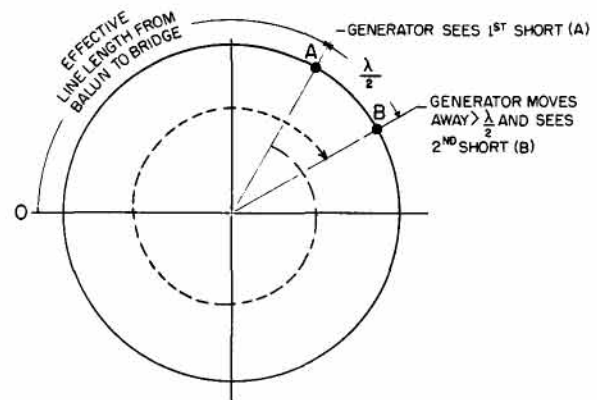

Figure 3-8.

The difference between the two impedances in absolute fractional wavelengths (as read on the chart periphery) are converted to units of measure based upon the frequency of interest, and the balun loop is trimmed by this amount, making it equal in length to an exact one-half wavelength.

**CHECKING THE BALUN.** The series resistor arrangement in Figure 3-7 may be used to check the impedance transformation and the balance of the balun with the 803A.

1) To check transformation, place two 100 ohm series resistors across balanced input connection, as shown. The Model 803A should read 50 ohms  $/0^\circ$ . The phase angle should be very nearly zero if the resistors have no reactive component.

2) To check balance, ground the center point of the two resistors. The reading should be the same as in step 1.



# SECTION IV THEORY AND MAINTENANCE

## 4-1 THEORY OF OPERATION

The basic circuit diagram for the Model 803A VHF Bridge is shown in Figure 4-1. The operation of the circuit is as follows:

Power of the desired frequency is fed through a coaxial line to the impedance under measurement. A magnetic probe and an electrostatic probe are located as close as possible to the end of the main line to determine the voltage to current ratio ( $E/I$ ), and thus the impedance. The voltage induced in the mag-

netic probe circuit is proportional to the current flowing at the sampling point, while the voltage in the electrostatic probe circuit is proportional to the voltage at the sampling point. These two small voltages,  $E_m$  and  $E_e$ , have a definite relationship to the impedance under test, and they are available for comparison purposes.

The MAGNITUDE control is ganged to adjust the depth of the two probes so that the induced voltages are equal in magnitude. The magnitude dial

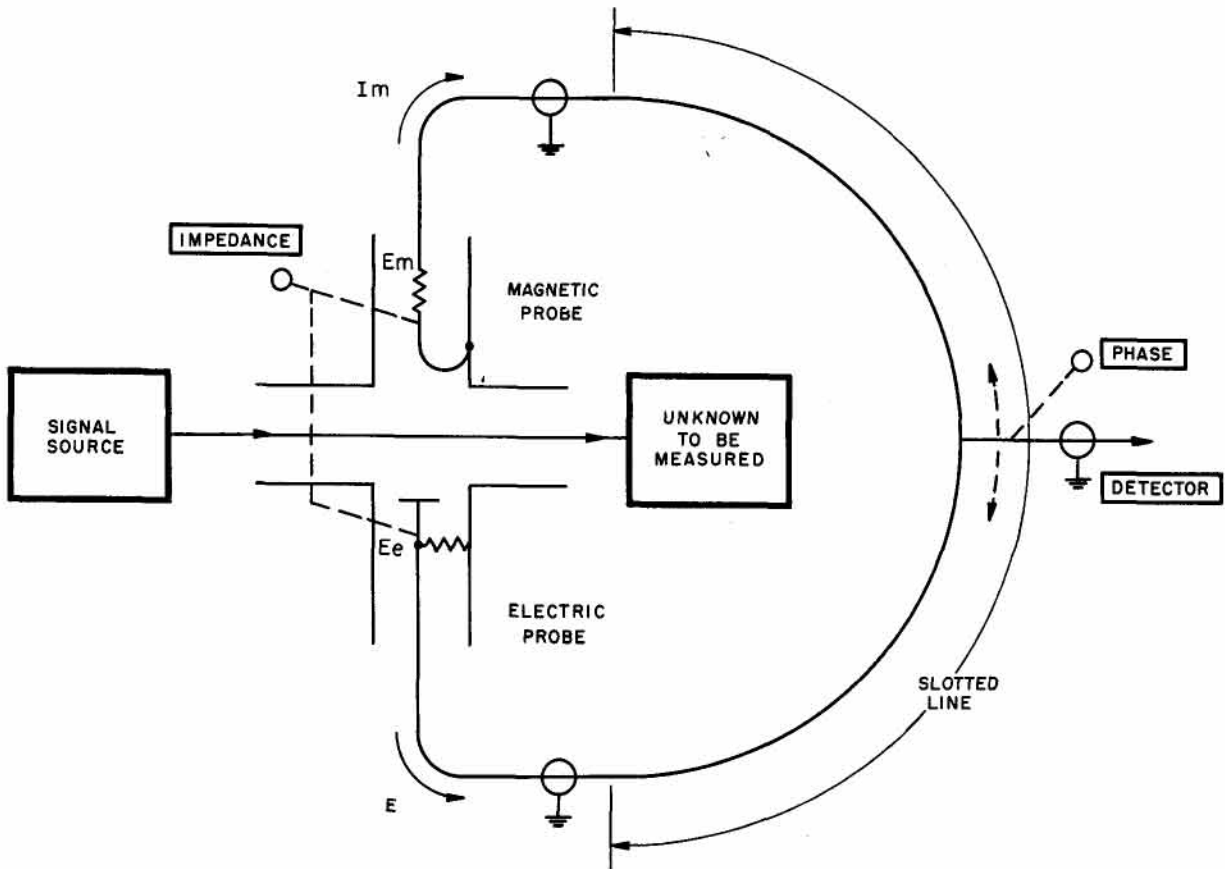

Figure 4-1. Theoretical Circuit Diagram

is calibrated to indicate the ratio of the balanced voltages in terms of impedance.

The phase angle of the impedance under test is determined by the angle between  $E_m$  and  $E_e$ . The null, found at the cancellation point of these two voltages, is detected by a probe sliding around a circular slotted section represented on the schematic as a loop. With a pure resistive load the current and voltage in the system will be in phase, but  $E_m$  and  $E_e$  will be out of phase, and when the pick-up probes are balanced the null will occur at the center of the slotted section with a dial indication of zero degrees phase angle.

With a reactive load the current and voltage in the system will not be in phase, and the null will be displaced to one side or the other of center in the slotted section. The amount and direction of displacement will depend upon the phase angle and nature of the reactive load.

#### 4-2 ACCURACY CHECK

The accuracy of the Model 803A may be checked by connecting the shorting plug supplied with the instrument to the UNKNOWN terminal and accurately setting the frequency of operation to

#### SHORT CIRCUIT IMPEDANCE CHART

For Serial \_\_\_\_\_.

Freq. MC	Z	$\theta$
60		
100		
200		
300		
400		
500		

those shown in the Short Circuit Impedance Chart below. When each frequency is set, balance the bridge and note the reading. These readings should agree within 1% of the tabulated readings shown in the table. For proper short circuit readings the shorting plug, supplied with the instrument, must be adjusted so that the red dot is at the top.

#### CAUTION

THERE IS NO REASON FOR REMOVING THE REAR COVER OF THE INSTRUMENT.

-----

Experience has shown that many bridges are damaged by removing the rear cover, particularly if the PHASE dial is not set to 45° before removing the cover.

#### 4-3 MAINTENANCE GENERAL

The overall calibration of the instrument is in part maintained by the setting of the various drive set screws. These screws should not be adjusted. If the accuracy check reveals that the instrument is out of calibration, consult your field sales engineer or write directly to the factory explaining the nature of the problem.

#### 4-4 LUBRICATION

The FRONT cover should be removed to lubricate the gears and attenuator pistons. DO NOT REMOVE THE REAR COVER. Lubrication once a year should be adequate.

A dry graphite or molybdenum disulfide powder is a preferred lubricant for the attenuator pistons. Apply sparingly with a small artist's brush.

The gears may be lubricated with a light moly grease, available from Hewlett-Packard under Stock No. 850-137.

DO NOT OVER LUBRICATE.

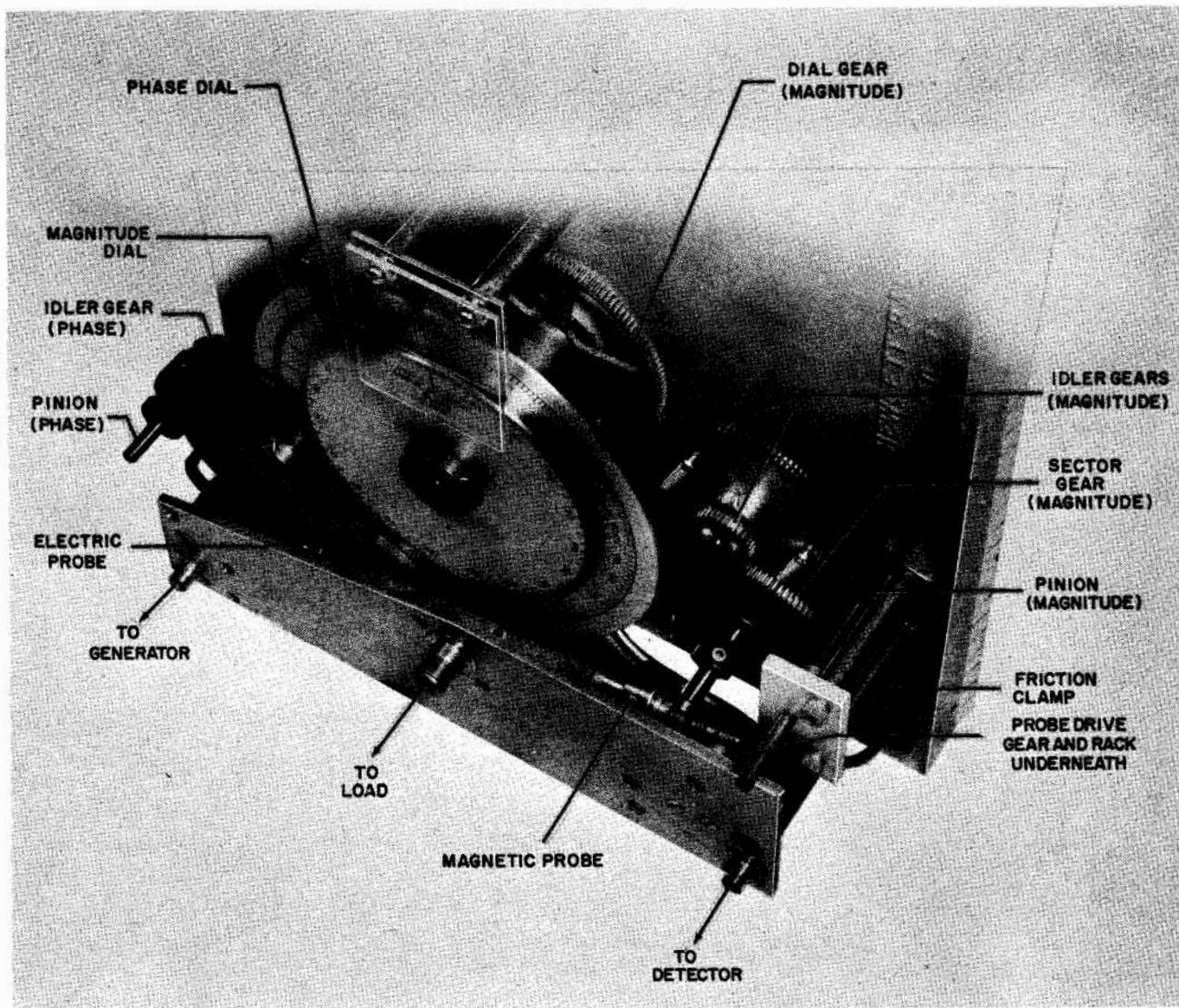

Figure 4-2. Front View, Case Removed



CAUTION: THERE IS NO REASON FOR REMOVING THE REAR COVER OF THE INSTRUMENT, AND YOU MAY DAMAGE THE INSTRUMENT BY REMOVING IT.

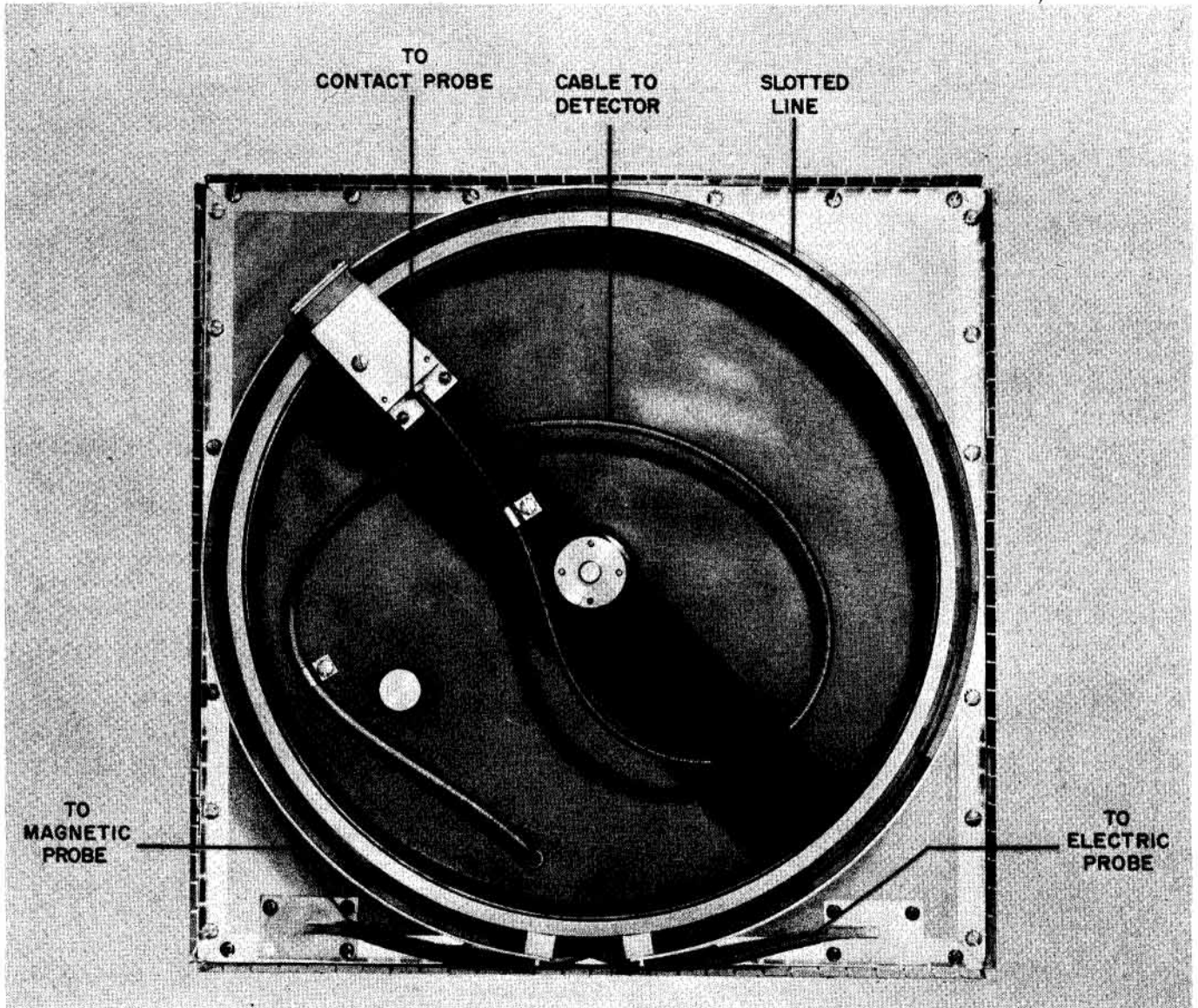



Figure 4-3. Rear View, Case Removed

## SECTION V TABLE OF REPLACEABLE PARTS

### NOTE

Standard components have been used in this instrument, whenever possible. Special components may be obtained from your local Hewlett-Packard representative or from the factory.

When ordering parts always include:

1.  Stock Number.
2. Complete description of part including circuit reference.
3. Model number and serial number of instrument.
4. If part is not listed, give complete description, function and location of part.

Corrections to the Table of Replaceable Parts are listed on an Instruction Manual Change sheet at the front of this manual.

### RECOMMENDED SPARE PARTS LIST

Column RS in the Table lists the recommended spare parts quantities to maintain one instrument for one year of isolated service. Order complete spare parts kits from the Factory Parts Sales Department. ALWAYS MENTION THE MODEL AND SERIAL NUMBERS OF INSTRUMENTS INVOLVED.

TABLE OF REPLACEABLE PARTS

CIRCUIT REF.	DESCRIPTION, MFR. * & MFR. DESIGNATION	STOCK NO.	TQ	RS		
	<u>NOTE</u>					
	For repair or readjustment, the Model 803A must be returned to the factory. Only the following parts can be replaced in the field.					
	Aluminum feet	HP* 61B-44L -1	2	1		
	Cable, external input	HP* 803A-16D	1	1		
	Cable, external output (copper shielded)	HP* 803A-16E	1	1		
	Escutcheon	HP* G-99E	1	1		
	Knob:	HP* G-74R	2	1		
	Rubber feet	HP* 39-17	2	1		

\* See "List of Manufacturers Code Letters For Replaceable Parts Table".

TQ - Total quantity used in the instrument.

RS - Recommended spares for one year isolated service for one instrument.

## LIST OF CODE LETTERS USED IN TABLE OF REPLACEABLE PARTS TO DESIGNATE THE MANUFACTURERS

CODE LETTER	MANUFACTURER	ADDRESS	CODE LETTER	MANUFACTURER	ADDRESS
A	Aerovox Corp.	New Bedford, Mass.	AK	Hammerlund Mfg. Co., Inc.	New York 1, N. Y.
B	Allen-Bradley Co.	Milwaukee 4, Wis.	AL	Industrial Condenser Corp.	Chicago 18, Ill.
C	Amperite Co.	New York, N. Y.	AM	Insuline Corp. of America	Manchester, N. H.
D	Arrow, Hart & Hegeman	Hartford, Conn.	AN	Jennings Radio Mfg. Corp.	San Jose, Calif.
E	Bussman Manufacturing Co.	St. Louis, Mo.	AO	E. F. Johnson Co.	Waseca, Minn.
F	Carborundum Co.	Niagara Falls, N. Y.	AP	Lenz Electric Mfg. Co.	Chicago 47, Ill.
G	Centralab	Milwaukee 1, Wis.	AQ	Micro-Switch	Freeport, Ill.
H	Cinch-Jones Mfg. Co.	Chicago 24, Ill.	AR	Mechanical Industries Prod. Co.	Akron 8, Ohio
HP	Hewlett-Packard Co.	Palo Alto, Calif.	AS	Model Eng. & Mfg., Inc.	Huntington, Ind.
I	Clarostat Mfg. Co.	Dover, N. H.	AT	The Muter Co.	Chicago 5, Ill.
J	Cornell Dubilier Elec. Co.	South Plainfield, N. J.	AU	Ohmite Mfg. Co.	Skokie, Ill.
K	Hi-Q Division of Aerovox	Olean, N. Y.	AV	Resistance Products Co.	Harrisburg, Pa.
L	Erie Resistor Corp.	Erie 6, Pa.	AW	Radio Condenser Co.	Camden 3, N. J.
M	Fed. Telephone & Radio Corp.	Clifton, N. J.	AX	Shallcross Manufacturing Co.	Collingdale, Pa.
N	General Electric Co.	Schenectady 5, N. Y.	AY	Solar Manufacturing Co.	Los Angeles 58, Calif.
O	General Electric Supply Corp.	San Francisco, Calif.	AZ	Seolectro Corp.	New Rochelle, N. Y.
P	Girard-Hopkins	Oakland, Calif.	BA	Spencer Thermostat	Attleboro, Mass.
Q	Industrial Products Co.	Danbury, Conn.	BC	Stevens Manufacturing Co.	Mansfield, Ohio
R	International Resistance Co.	Philadelphia 8, Pa.	BD	Torrington Manufacturing Co.	Van Nuys, Calif.
S	Lectrohm Inc.	Chicago 20, Ill.	BE	Vector Electronic Co.	Los Angeles 65, Calif.
T	Littlefuse Inc.	Des Plaines, Ill.	BF	Weston Electrical Inst. Corp.	Newark 5, N. J.
U	Maguire Industries Inc.	Greenwich, Conn.	BG	Advance Electric & Relay Co.	Burbank, Calif.
V	Micamold Radio Corp.	Brooklyn 37, N. Y.	BH	E. I. DuPont	San Francisco, Calif.
W	Oak Manufacturing Co.	Chicago 10, Ill.	BI	Electronics Tube Corp.	Philadelphia 18, Pa.
X	P. R. Mallory Co., Inc.	Indianapolis, Ind.	BJ	Aircraft Radio Corp.	Boonton, N. J.
Y	Radio Corp. of America	Harrison, N. J.	BK	Allied Control Co., Inc.	New York 21, N. Y.
Z	Sangamo Electric Co.	Marion, Ill.	BL	Augat Brothers, Inc.	Attleboro, Mass.
AA	Sarkes Tarzian	Bloomington, Ind.	BM	Carter Radio Division	Chicago, Ill.
BB	Signal Indicator Co.	Brooklyn 37, N. Y.	BN	CBS Hytron Radio & Electric	Danvers, Mass.
CC	Sprague Electric Co.	North Adams, Mass.	BO	Chicago Telephone Supply	Elkhart, Ind.
DD	Stackpole Carbon Co.	St. Marys, Pa.	BP	Henry L. Crowley Co., Inc.	West Orange, N. J.
EE	Sylvania Electric Products Co.	Warren, Pa.	BQ	Curtiss-Wright Corp.	Carlstadt, N. J.
FF	Western Electric Co.	New York 5, N. Y.	BR	Allen B. DuMont Labs	Clifton, N. J.
GG	Wilkor Products, Inc.	Cleveland, Ohio	BS	Excel Transformer Co.	Oakland, Calif.
HH	Amphenol	Chicago 50, Ill.	BT	General Radio Co.	Cambridge 39, Mass.
II	Dial Light Co. of America	Brooklyn 37, N. Y.	BU	Hughes Aircraft Co.	Culver City, Calif.
JJ	Leecraft Manufacturing Co.	New York, N. Y.	BV	International Rectifier Corp.	El Segundo, Calif.
KK	Switchcraft, Inc.	Chicago 22, Ill.	BW	James Knights Co.	Sandwich, Ill.
LL	Gremar Manufacturing Co.	Wakefield, Mass.	BX	Mueller Electric Co.	Cleveland, Ohio
MM	Carad Corp.	Redwood City, Calif.	BY	Precision Thermometer & Inst. Co.	Philadelphia 30, Pa.
NN	Electra Manufacturing Co.	Kansas City, Mo.	BZ	Radio Essentials Inc.	Mt. Vernon, N. Y.
OO	Acro Manufacturing Co.	Columbus 16, Ohio	CA	Raytheon Manufacturing Co.	Newton, Mass.
PP	Alliance Manufacturing Co.	Alliance, Ohio	CB	Tung-Sol Lamp Works, Inc.	Newark 4, N. J.
QQ	Arco Electronics, Inc.	New York 13, N. Y.	CD	Varian Associates	Palo Alto, Calif.
RR	Astron Corp.	East Newark, N. J.	CE	Victory Engineering Corp.	Union, N. J.
SS	Axel Brothers Inc.	Long Island City, N. Y.	CF	Weckesser Co.	Chicago 30, Ill.
TT	Belden Manufacturing Co.	Chicago 44, Ill.	CG	Wilco Corporation	Indianapolis, Ind.
UU	Bird Electronics Corp.	Cleveland 14, Ohio	CH	Winchester Electronics, Inc.	Santa Monica, Calif.
VV	Barber Colman Co.	Rockford, Ill.	CI	Malco Tool & Die	Los Angeles 42, Calif.
WW	Bud Radio Inc.	Cleveland 3, Ohio	CJ	Oxford Electric Corp.	Chicago 15, Ill.
XX	Allen D. Cardwell Mfg. Co.	Plainville, Conn.	CK	Camloc-Fastener Corp.	Paramus, N. J.
YY	Cinema Engineering Co.	Burbank, Calif.	CL	George K. Garrett	Philadelphia 34, Pa.
ZZ	Any brand tube meeting RETMA standards.		CM	Union Switch & Signal	Swissvale, Pa.
AB	Corning Glass Works	Corning, N. Y.	CN	Radio Receptor	New York 11, N. Y.
AC	Dale Products, Inc.	Columbus, Neb.	CO	Automatic & Precision Mfg. Co.	Yonkers, N. Y.
AD	The Drake Mfg. Co.	Chicago 22, Ill.	CP	Bassick Co.	Bridgeport 2, Conn.
AE	Elco Corp.	Philadelphia 24, Pa.	CQ	Birnbach Radio Co.	New York 13, N. Y.
AF	Hugh H. Eby Co.	Philadelphia 44, Pa.	CR	Fischer Specialties	Cincinnati 6, Ohio
AG	Thomas A. Edison, Inc.	West Orange, N. J.	CS	Telefunken (c/o MVM, Inc.)	New York, N. Y.
AH	Fansteel Metallurgical Corp.	North Chicago, Ill.	CT	Potter-Brumfield Co.	Princeton, Ind.
AI	General Ceramics & Steatite Corp.	Keasbey, N. J.	CU	Cannon Electric Co.	Los Angeles, Calif.
AJ	The Gudeman Co.	Sunnyvale, Calif.	CV	Dynac, Inc.	Palo Alto, Calif.
			CW	Good-All Electric Mfg. Co.	Ogallala, Nebr.